



NEW PRODUCT RELEASE - True 75 ohm 3GHz Mini BNC Connectors

True 75 Ohm Mini BNC co-axial connector range for 3G-HD Serial Digital applications.

This true 75 ohm mini BNC connector range has been engineered by Cambridge Connectors to operate in 3G-SDI broadcast environments where its compact size makes it invaluable in high density wiring applications such as routing and switching equipment.

Features

- For use in SDI, HDI, 3G-SDI digital broadcast applications
- 12mm pitch offers compact dimensions
- Already used in broadcast industry

Specification -

Electrical

Impedance	75 Ohm
Frequency Range	0 - 3.0 GHz
Working Voltage	300Vrms
Dielectric Withstanding Voltage	1500Vrms

Reflection Factor

	DC-1.5GHz (VSWR)	1.5 - 3.0 GHz (VSWR)
Top Entry Mini BNC	1.08	1.13
Right Angle Mini BNC	1.04	1.16
2 Part Mini BNC	1.05	1.07
Edge Mount Mini BNC	1.05	1.06

Contact Resistance	Centre Contact 12.0 m ohm
Insulation Resistance	> 1000 meg ohm

Materials

Centre Pin	Phosphor Bronze / 10u" Au
Body finish	Standard — Brass/Ni
Insulators (R/A version)	TPX
Insulators (All others)	PTFE

Environmental

Temperature Range	-65 to +85° C
Mating Cycles	500

Cambridge Connectors™

A division of Cambridge Electronic Industries Ltd.
Denny Industrial Centre, Waterbeach, Cambridge, England, CB25 9QR
Tel: +44 (0)1223 860041 Fax: +44 (0)1223 863625
Email: sales@cambridgeconnectors.com
Web: www.cambridgeconnectors.com

Cambridge Connectors and the globe symbol are trademarks of Cambridge Electronic Industries Ltd., Cambridge, England.
© Cambridge Electronic Industries Ltd. 2008 –2009

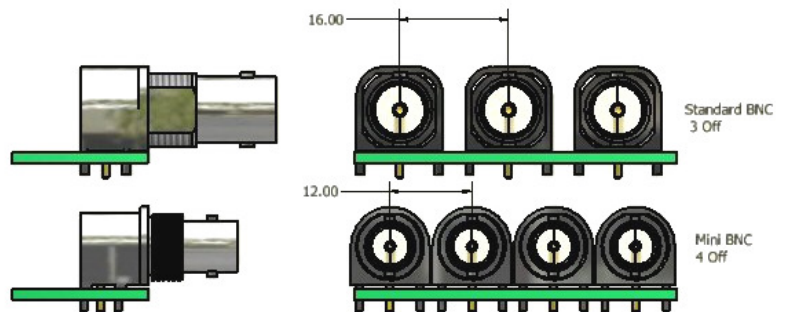
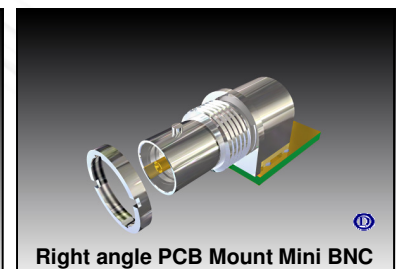
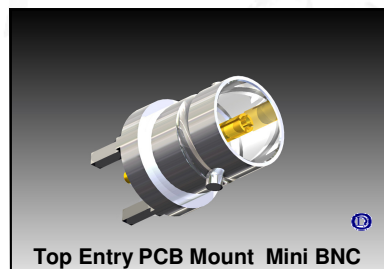
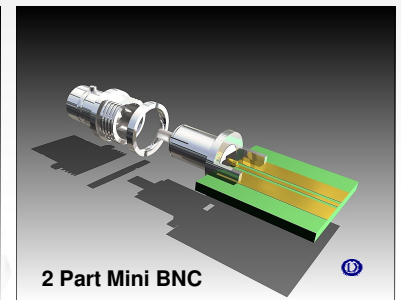
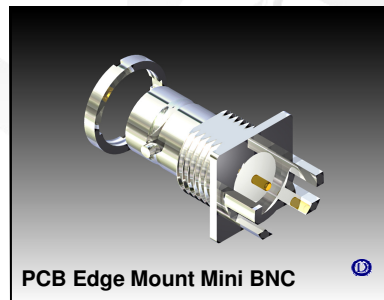

Pitch comparison between Standard BNC and Mini BNC Connectors

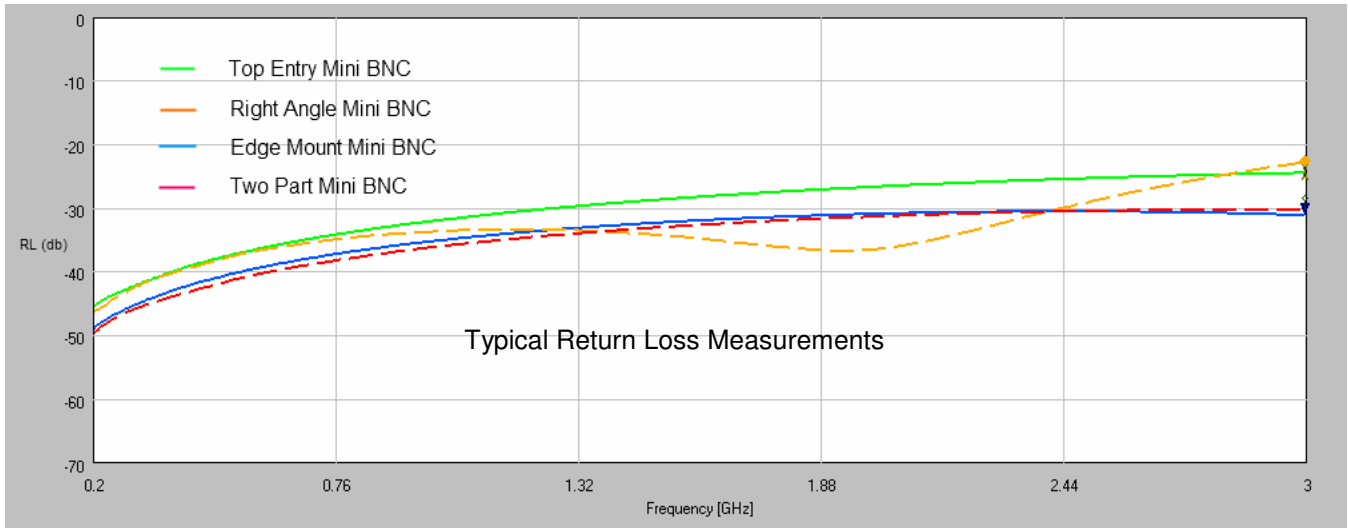

For further information or technical support contact our authorised representatives: —

Canada

J-Squared Technologies Inc.

Toronto Office

14-145 Traders Blvd
Mississauga, ON
Canada L4Z 3L3
Phone: 905.501.7573
Email: harminder@jsquared.com

Ottawa Office

101-4015 Carling Avenue
Kanata, ON
Canada K2K 2A3
Phone: 613.592.9540
Email: rhowell@jsquared.com

Montreal Office

180-1255 Trans Canada Hwy
Dorval, QC
Canada H9P 2V4
Phone: 514.421.5560
Email: sylvie@jsquared.com

Calgary Office

1935, 32nd Ave. NE, Suite 251
Calgary, AB
Canada T2E 7C8
Phone: 403.207.5526
Email: iwellman@jsquared.com

USA

Ewing-Foley

Cupertino Office

10061 Bubb Road
Cupertino, CA 95014
T 408 342-1220
F 408 342-1221
Email: cfraser@ewingfoley.com
Area: San Francisco Bay Area

Sacramento Office

13620 Lincoln Way, Suite 100
Auburn, CA 95603
T 530 885-6591
F 530 885-6594
Email: msmothers@ewingfoley.com
Area: Sacramento, Grass Valley, Auburn, Reno, Fresno

Infinity Sales

Los Angeles Office

21800 Burbank Blvd. #140
Woodland Hills, CA 91367
Phone: 818-444-6250
Fax: 818-444-6257

Email: gayle@infinitysales.com

Area: San Fernando Valley, Santa Barbara, Ventura, Los Angeles Counties, Hawaiian Islands

Tustin Office

3002 Dow Avenue Suite 306
Tustin CA 92780
Phone: 714-669-8520
Fax: 714-838-6408
Email: Cathy.latham@infinitysales.com
Area: San Gabriel Valley, Riverside, Temecula, Orange, San Bernadino Counties

J-Squared Technologies Inc.

Portland Office

1 Lincoln Center
10300 SW Greenburg Road,
Suite #525
Portland, OR 97223
Phone: 503.473.8407
Email: davidr@jsquarednw.com

Seattle Office

103-12233 116th Avenue North
Kirkland, WA 98034
Phone: 425.821.0888
Email: mikes@jsquarednw.com

Florida East Office

54 Live Oak Road
Winter Garden, FL 34787
Phone: 407.347.8064
Email: eric.forsberg@jsquaredse.com

Florida West Office

11134 Wirt Rd
San Antonio, FL 33576
Phone: 352.588.9951
Fax 813-433-5663
Email: bob.zimmerman@jsquaredse.com

RA Sales

Georgia Office

PO Box 1112, 3147
Overlook Terrace,
Snelville, GA30078
Tel: 770 736 7291
Fax: 770 736 7301
email: rasalesbc@aol.com
Area: Georgia, S. Alabama & S. Mississippi

N Carolina Office

15 Scenic View Drive,
Weaverville, NC28787-9370
Tel: 828 243 2944
Fax: 828 658 2699

email: steveregion@aol.com

Area: N. Carolina & S. Virginia

Todino Engineering Sales

New England Office

PO Box 17455
15 Higgins Street, Unit 301
Smithfield, RI 02917
Phone: 401.233.9501
Fax: 401.233.9502
Email: todinoengr@aol.com
Area: Rhode Island, Massachusetts, Connecticut, New Hampshire, Maine, Vermont, New York State, New Jersey, Eastern Pennsylvania

Europe

L2Tek

6 Cavendish Gardens
Church Crookham
Fleet, Hants, UK, GU52 6PD
Phone: +44 (0)7515-282-184
Phone: +44 (0)7515 282 185
Email: mark@l2tek.co.uk
Email: tim@l2tek.co.uk
Area: UK and Scandinavia

Head Office

Cambridge Connectors
A division of Cambridge Electronic Industries Ltd.

Denny Industrial Centre,
Waterbeach, Cambridge,
England, CB25 9QR

Tel: +44 (0)1223 860041

Fax: +44 (0)1223 863625

Email: Sales@cambridgeconnectors.com

www.cambridgeconnectors.com

